

**PSH Commercial pool pump
cast iron DN125 x DN100
flange 10,1A 400/690VAC
black type FDN3000-20
(7029859)**



 P S H

TECHNICAL SPECIFICATIONS

Colour	black
Shaft	stainless steel 316L
Pump body	cast iron
Material impeller 1	bronze/aluminium
Material cover	cast iron
Material seal	carbon/ceramic
Connection	flange
Frequency	50 Hz
IP value	IP55
Motor RPM	2900
Type	FDN3000-20
Capacity	152 m ³ /h
Output Power	7,5 HP
MWC	18 m
Size	DN125 x DN100
Length	1071 mm
Voltage	400/690VAC

Width 312 mm

Weight 99 kg

Power 5.5 kW

Height 360 mm

Ampere 10,1 A

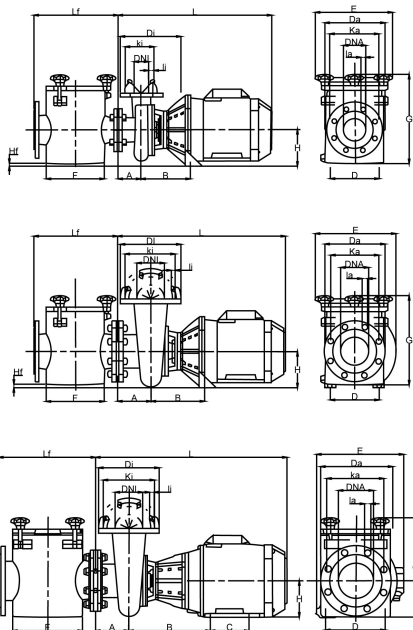

PART NO.	Da	Ka	la	Di	Ki	li	A	B	C	D	E	F	G	H	HF	L	LF
7029850	200	160	19	152	125	14	82	172	-	140	271	210	319	132	12	491	300
7029851	200	160	19	152	125	14	82	172	-	140	271	210	319	132	12	491	300
7029852	200	160	19	152	125	14	82	182	-	190	271	210	319	132	-	533	300
7029853	220	180	19	220	180	19	120	196	-	190	288	210	320	132	-	584	300
7029854	220	180	19	220	180	19	120	196	-	190	288	210	320	132	-	606	300
7029855	220	180	19	220	180	19	120	196	-	190	288	210	320	132	-	606	347
7029856	250	210	19	220	180	19	120	196	-	190	275	250	347	132	-	606	347
7029857	250	210	19	220	180	19	120	196	-	190	275	250	347	132	-	606	347
7029858	250	210	19	220	180	19	120	292	140	216	312	250	360	132	-	724	347
7029859	250	210	19	220	180	19	120	292	140	216	312	250	360	132	-	724	347
7029860	250	210	19	220	180	19	120	292	140	216	312	250	360	132	-	724	347
7029861	250	210	19	220	180	19	120	292	140	216	312	250	360	132	-	724	347

PRODUCT INFORMATION

FDN-3000 is a pool pump designed to offer the highest performance in filtration and purification of water for commercial pools. All parts in contact with water are treated using a long lasting cataphoresis process. This treatment prevents the formation of troublesome oxides on cast iron

pumps significantly prolonging the life of cast iron and is one of the best anti corrosion and antioxidant treatments existing in today's market.

Features:

- High efficiency motor class IE3 according to regulation EC n°640/2009
- Special long life treatment to prevent corrosion
- Standard motor which makes it compatible with any manufacturer's engine worldwide
- Robust and durable
- High quality mechanical seal and bearings
- Independent pre filter allowing use of the pump without prefilter or assembly to other types of pre filters
- Pre filter with large volume and stainless steel basket with easy access for cleaning

Last modified date: 08/05/2026

Bosta UK Ltd.
Reflection House
Olding Road
Bury St. Edmunds
Suffolk
IP33 3TA
T +44 (0) 1284 716580
E enquiries@bosta.co.uk
<http://www.bosta.com>